

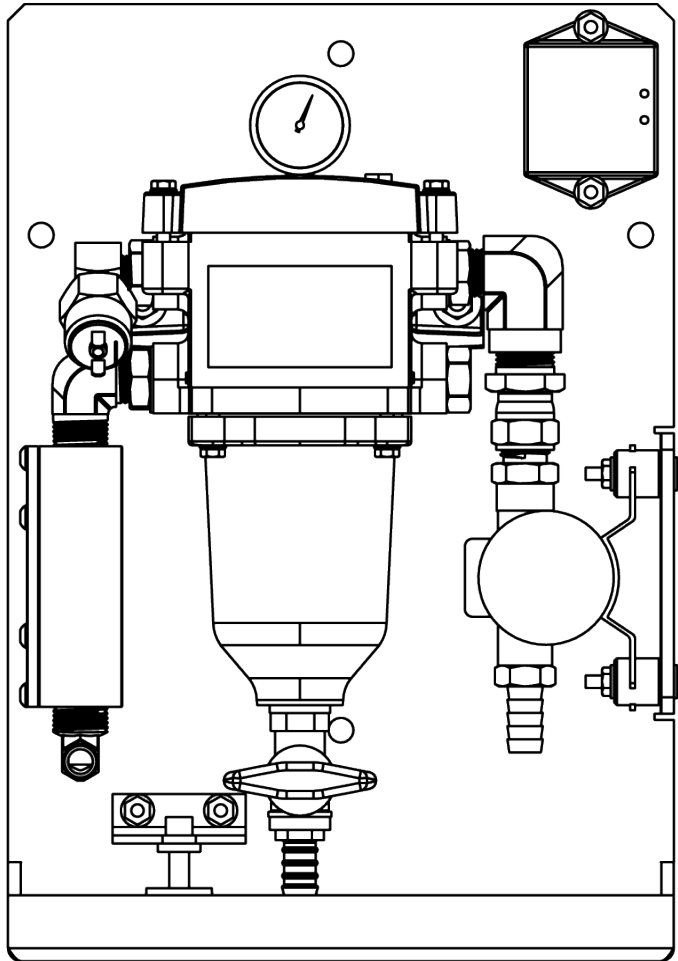

# **FPS Compact Instruction, Operating, & Maintenance Manual**

**COMPACT FUEL MAINTENANCE SYSTEM**

*REV0302COM010120*





# Table of Contents

<b>Table of Contents</b> .....	<b>2</b>
<b>General Overview</b> .....	<b>3</b>
FPS Compact Specifications .....	3
<b>System Components</b> .....	<b>4</b>
Control and Safety Devices .....	4
Pump/Motor .....	4
Primary Filter/Water Separator .....	4
Fuel Conditioner .....	4
Plumbing .....	4
<b>System Operation</b> .....	<b>5</b>
Pump Operation .....	5
Alarms .....	5
<b>Primary Inspection</b> .....	<b>6</b>
Checklist .....	6
<b>Installation</b> .....	<b>7</b>
Mounting .....	7
Electrical .....	7
Plumbing .....	7
Typical Plumbing Installation (Schematically) .....	8
Important Installation Precautions .....	8
<b>Controller</b> .....	<b>9</b>
Setting the Current Date and Time .....	9
Programming the Timer .....	9
<b>Priming the System</b> .....	<b>10</b>
Priming Procedure .....	10
<b>Commissioning/Initial Start-Up</b> .....	<b>11</b>
Gauge Venting .....	11
Switch Adjustments .....	11
Initial Test Procedures .....	11
<b>Maintenance</b> .....	<b>12</b>
Preventative Maintenance .....	12
Servicing the Primary Filter/Water Separator .....	12
Replacement Filter Chart .....	13
<b>Troubleshooting</b> .....	<b>14</b>
Symptom Troubleshooting Guide .....	14
<b>AXI International Limited Warranty</b> .....	<b>15</b>
Warranty Claim Procedure .....	16
<b>Technical Assistance and Ordering</b> .....	<b>17</b>
Replacement Filter Elements .....	17
FPS Compact System Identification .....	17

# General Overview

## FPS Compact Specifications

Flow Rate.....	1.3 GPM/80 GPH (5 LPM/302.8 LPH) 640 gallons (2,423liters) per 8-hour shift 1,920 gallons (7,268 liters) per 24 hours
Primary Filter.....	10 or 30 $\mu$ Particulate or 60 $\mu$ Stainless Steel Screen with Centrifugal Water Separator
Fuel Conditioner.....	LG-X 500 Inline Magnetic Conditioner
Plumbing.....	Stainless Steel
Inlet Port.....	1/2" Hose Barb
Outlet Port.....	1/2" Hose Barb
System Back Plate.....	Powder Coated Aluminum
Operating Temperature.....	41 - 104°F (5 - 40°C)
Electrical.....	12VDC/10A or 24VDC/5A
Pump.....	DC Gear Pump
Suction Capability (Primed).....	10 ft. (304.8 cm) Total Dynamic Head
Timer.....	Programmable Digital Timer
Maximum Fluid Viscosity.....	5 cSt
Outline Dimensions.....	≈ 14" x 10" x 8" (36 x 25 x 20 cm) (H x W x D)
Weight.....	≈ 20lbs. (9.1kg)

**!WARNING! This system is not meant for use with gasoline or any other flammable liquids having a flash point less than 100°F (37.8° C). Use with gasoline or any flammable liquids at a temperature exceeding their flash point presents an immediate explosion and fire hazard.**



# System Components

## Control and Safety Devices

- System Controller
  - Programmable Digital Timer
  - Memory retention during power outages
  - Alarm Indicator Light(s)
  - Breaker (Power On/Off switch)
- Water Detection Alarm Module
- Vacuum Switch
- Leak Detection Float Switch

## Pump/Motor

- DC Gear Pump

## Primary Filter/Water Separator

- Fuel Filter
  - Standard-issue back-flushable 30-micron hydrophobic filter cartridge (other filter elements available)
- Water Separator
- One Pair of Water Detection Sensor Probes
- Drain Valve - on the bottom

## Fuel Conditioner

- Inline Magnetic Fuel Conditioner

## Plumbing

- Stainless Steel



# System Operation

Apply control power to unit. Place breaker for the System Controller in the “ON” position.

## Pump Operation

### Automatic Mode:

Press the ‘MANUAL’ button on the System Controller until ‘AUTO’ is indicated on the display. When the timer contacts close, the pump will start and run until the scheduled timer setting has expired. See the *Controller* section for setting the timer for scheduled run times.

### On Mode:

Press the ‘MANUAL’ button on the System Controller until ‘ON’ is indicated on the display. The pump motor will run until the system is switched off, into “Auto” mode, or an alarm has been tripped.

## Alarms

### Alarms featured on the system include:

- Leak Detection (system shutdown, alarm indication)
  - Activated when the Float Switch in the system’s drip tray detects a raised liquid level. The system will go into an alarm state and the pump will not be allowed to be run until the alarm is addressed and cleared.

**Note: Disposal of fuel and associated waste should be done in accordance with Federal, State and Local regulations.**

- High Vacuum (system shutdown, alarm indication)
  - Activated when the Vacuum Switch, placed on the suction side of the pump set, detects a reading above the factory set point (12” HG). The system will go into an alarm state and the pump will not be allowed to run until the alarm is addressed and reset.
- High Water (system shutdown, alarm indication)
  - Activated when water level trips the Water Detection Alarm Module via the Water Detection Sensor Probes located on the mechanical water separator.

Once triggered alarms are addressed, each alarm can be reset via the System Controller.



## Primary Inspection

Upon arrival, the system and accessories must be visually inspected before installation. Improper handling during shipping may cause physical or electrical problems. Immediately report or note any damages to the shipper.

### Checklist

- If the packing crate shows signs of damage inspect the system for damage.
- Check the entire system for damage that could indicate internal mechanical or electrical problems.
- Check pump/motor hardware and all plumbing connections for tightness.
- Check all electrical terminals and connections for tightness.

# Installation

**Note:** It is recommended that only qualified, experienced personnel, familiar with this type of equipment, who have read and understood all the instructions in this manual should install, operate, and maintain the system.

## Mounting

The unit should be permanently wall mounted on a hard, level surface. Use provided mounting holes located on the back plate for proper fastening (Refer to mechanical drawing(s) for Mounting Hole Diameter). Ensure the system is level and secure, enabling water to be more accurately sensed in the primary filter's sump. Be sure to secure the system in a location that allows all piping and electrical wiring to be safely routed to the system. This unit is designed for well-ventilated indoor use within the specified temperature range and should be located as close to the tank as possible.

## Electrical

**!WARNING! To avoid the risk of electric shock, make sure that the power supply to the system is disconnected and ensure that the system is at zero volts, before working on any of the system's electrical parts.**

Make sure that the system's power requirements and rated voltage/frequency match your electrical system (see wiring diagram). The system may only be connected to properly grounded power sources for operator safety. Connect all components to the ground studs provided as shown on the provided drawings. The system connects to either 12VDC or 24VDC with the positive lead from your power source to the red wire and the negative lead to the gray wire. After the initial wiring of the system check operation to ensure that it is running in the correct direction. If the motor is running in the wrong direction, contact AXI International immediately.

**!WARNING! The whole system (enclosure, doors, plumbing, motor, electric sub panel) must be properly grounded for operator safety.**

Depending on length of run, use wiring according to specification in wiring diagram and connect system to a separate UL listed breaker (not included) appropriate for branch circuit protection. Connect the System Controller to the filtration unit with the provided plugs and wiring harnesses.

**Note:** Wiring and electrical installation must be in accordance with all applicable federal, state, and local rules, laws, standards, and regulations.

## Plumbing

**Note:** Please ensure to check all of the plumbing (joints, unions, miscellaneous fittings) for tightness prior to completion.

Use proper quality approved fuel line materials with similar inner diameter (ID) to the inlet/outlet of the system. For extended suction side plumbing runs, it is recommended to install oversized pipe, (1/4" to 1/2" increased ID) (Ref.: Page 4 – Suction Capability). **It is imperative that external, manual inlet and outlet ball valves be installed on each side of the filtration system. That will enable it to be isolated from the external piping apparatus, eliminating the possibility of the system to be damaged by over-pressurization of said plumbing during initial start-up testing (IST).**

**Note:** Flexible plumbing is strongly recommended for system inlet and outlet connections to external plumbing in order to avoid issues with thermal expansion, prevent putting any stress on the internal fittings of the system, and enable ease of maintenance/installation. Install manual inlet and outlet ball valves prior inlet flexible plumbing and post outlet flexible plumbing respectively.

The pick-up tube/line(s) should originate from the lowest point of the tank to ensure all water is removed. Also, it should be connected directly to the system's inlet port (located on the left-hand side of the system) and be kept as short as possible. It is recommended that an oversized, low restriction foot valve be installed to keep the system primed, especially





if the inlet port of the system is located above the lowest possible level of fuel in the tank. Additionally, a priming tee should be installed at the highest point of the suction line to enable priming of the pipelines and system.

The return line(s) should be plumbed to the system's outlet port (located on the right-hand side of the system) and enter the tank as far as possible away from the pick-up tube, close to the tank bottom.

Multiple suction and/or return lines may be connected to a manifold outside the system.

**Note: Anti-Siphon or other external plumbing devices may be required by state and/or local regulations & code.**

Cumulatively, the system capabilities are 10 FT. (3.05 m) suction (vertical lift), when connected to the minimum recommended piping size (Ref.: Page 4 – Inlet/Outlet Port), or more, with no additional flow restrictions. That includes valves, 90-degree connectors, or other plumbing accessories. For continuous optimal performance, make sure suction and discharge lines are free of contamination, nothing is blocking the flow of fuel, and the suction line always stays primed.

**Note: Plumbing installation must be in accordance with all applicable federal, state, and local rules, laws, standards, and regulations.**

## Typical Plumbing Installation (Schematically)

See provided P&ID drawing(s).

## Important Installation Precautions

The suction line of the system should be independent and separate from the suction line of the engine. If that is not possible, appropriate valves must be installed separate to the system from the engine fuel system to prevent any possible interference with safe engine operation.

It is highly recommended to plumb the discharge line independent and separate of the engine's fuel return line back to the tank. If the return line from the engine and the discharge of the system must be combined in any way, adequate valves should be installed to prevent any possible interference with safe engine operation.



# Controller

## Setting the Current Date and Time

1. Press and hold the 'CLOCK' button.
2. Proceed to press sequentially, 'DAY', 'HOUR' and 'MIN' button to adjust clock of timer to correct date, hour and minute.

## Programming the Timer

1. Press the 'TIMER' button. LCD screen will switch to the first timer (1ON)
2. Press 'DAY' as often as required to select any of the 15 combinations of days that suit your application
3. Press 'HOUR' and 'MIN' respectively to set desired start time for 1ON
4. Press 'TIMER' to switch to 1OFF
5. Press 'DAY' as often as required to select the same combinations of days as in step 2 (must be consistent)
6. Press 'HOUR' and 'MIN' respectively to set desired stop time for 1OFF
7. Repeat procedure (step 1 through 6) if you would like to set several timers
8. When finished programming press 'CLOCK'

To review the program press 'TIMER' button repeatedly to go through all 8 timers.

To activate the timer program, make sure to press 'MANUAL' button will the display indicated you are in AUTO mode.

Please call AXI International with any questions.



## Priming the System

The pump supplied with the system is NOT automatically self-priming and must not be run dry.

**!WARNING! If the pump is allowed to run without fuel, pump damage will occur.**

### Priming Procedure

The pump head of the unit is shipped from the factory filled with oil to facilitate initial lubrication. This will not eliminate the necessity to prime the complete system. The system is primed through the primary filter as well as the suction line(s) have to be completely filled with fuel (no trapped air) prior to the initial system start-up.

The system is equipped with a vacuum switch on the input side of the pump. When the pump inlet vacuum reaches 12" HG the system will shut down and activate the "HIGH VACUUM ALARM". This indicates excessive debris, a flow restriction, or too high suction height and therefore pressure drop in the suction line.

# Commissioning/Initial Start-Up

## Gauge Venting

After shipment, gauge pointers may not rest at zero due to internal case pressure build-up, which is caused by temperature and/or pressure variations. As a result, their accuracies may be significantly reduced. To restore the gauges to operating condition, move the yellow lever of the fill plug to the open position or remove the black rubber piece from top of gauge and leave it open to vent.

## Switch Adjustments

**Note:** Please contact AXI International before adjusting either the vacuum or the pressure switch to avoid voiding the system's warranty.

### Vacuum Switch

When the value exceeds the set point of the switches' rating, the switch will change state. Ensure you are working with a normally closed position (leads on opposite sides of the switch – across from one another are connected to the wire spades). If the set point is incorrect, adjustments can be performed in the field as follows:

1. Remove the two wires connected to the normally closed spades on the top of switch.
2. Pop off the "Rubber Plug" in between the spades on top of the switch.
3. Insert a 5/64" Allen Wrench/Key into the slot.
4. Adjust the Wrench/Key  $\frac{1}{4}$  -  $\frac{1}{2}$  turn at a time CCW to increase the vacuum alarm's set point.
5. After adjusting the settings, perform the testing procedure(s) for the switch(es) as outlined in the commissioning section.

## Initial Test Procedures

**With breakers and power turned on, and pump running, check all alarms for proper operation:**

- **Leak Detection** - Manually raise the float switch located at the bottom of the leak-basin. Pump should immediately turn off, and the "Leak Detection" alarm should be indicated on the System Controller. Reset the alarm by pushing or selecting the "Alarm Reset" on the System Controller.
- **High Vacuum Alarm** - Slowly, partially close inlet ball valve. At 12" HG, the pump(s) should turn off and the "High Vacuum" alarm should be indicated on the System Controller. Open the inlet ball valve again. Reset the alarm by pushing or selecting the "Alarm Reset" on the System Controller.
- **Water Sensor** - Jump the Water Detection Sensor Probes water sensor probes by placing a piece of conductive metal across the two horizontal contacts. The pump should turn off and the "Water Sensor" alarm should be indicated on the System Controller. Remove the metal and reset the alarm by pushing or selecting the "Alarm Reset" on the System Controller.

**Note:** If any of the above described alarm test procedures fail or if any alarm trip value deviates, immediately contact AXI International.

# Maintenance

The system should be visually inspected and tested a minimum of every six (6) months according to the procedure below during light duty cycles. Monthly inspections are recommended for systems that are being used in excess of an average of eight (8) hours day and five (5) days a week.

## Preventative Maintenance

**Prior to performing the maintenance procedure ensure that:**

1. The electrical sub-panel mounted main disconnect switch is operating properly
2. The user supplied remote circuit breaker is in the “OFF” position
3. All sources of power are isolated from the unit

**Note: Proceed only after this has been verified and properly tagged.**

4. Drain visible water and sediment from primary filter/water separator (see Servicing Primary Filter/Water Separator)
5. Check system and all parts for corrosion and rust
6. Check mounting hardware – tighten as necessary
7. Check bolts on the pump/motor hardware for tightness, as pump/motor hardware can loosen after normal operation for extended durations of time, due to vibration.
8. The hardware uses lock nuts – check all bolts for secure nuts
9. Check all electrical terminals and connections for tightness
10. All motors are permanently lubricated and do not require any lubrication
11. Check all plumbing joints for leaks, tighten fittings and joints as necessary, and remove accumulated fuel in leak-basin as necessary
12. Inspect all filter(s) and separator(s)

**Note: All filter elements should be replaced at least every six (6) months.**

## Servicing the Primary Filter/Water Separator

Clogged filter elements restrict the flow of fuel, resulting in the system’s vacuum gauge indicating a pressure drop. The gauge is mounted between the primary filter and the pump. At a pressure drop of 12” HG, the pump will automatically shut off and activate the “ALARM LIGHT” indicator. The signal indicates that it is time to either back flush or change the filter element.

**Servicing and back-flushing primary filter:**

1. Press the ‘MANUAL’ button on the System Controller until ‘OFF’ is indicated on the display – making sure the pump will not turn on
2. Close the inlet and outlet ball valve
3. Open the bleed screw at the top of the primary filter cover
4. Place a fuel waste container below the yellow safety drain valve on the bottom of the filter bowl (unless system is equipped with optional Automatic Water Drain)
5. Open the yellow safety drain valve (push & turn counterclockwise)
6. Close after approximately 2 seconds
7. After approximately 10 seconds, reopen the drain valve (allows water to settle out of the fuel)
8. Close after visible sediment, particles, and water have been drained from the bowl
9. If the filter requires changing, remove the filter from the housing by removing the four bolts that hold the top plate in place. Remove the spring-loaded cartridge and replace the filter.
10. Prime the filter by following the instructions found in the Priming section of this manual
11. Replace the lid. Note: Evenly tighten the bolts to ensure a good seal
12. Close bleed screw on top of the lid

13. Open the inlet and outlet ball valve on the system
14. Push the “ALARM RESET” button on the control panel to acknowledge the alarm and reset it
15. Press the ‘MANUAL’ button on the System Controller until ‘AUTO’ or ‘MANUAL’ are indicated on the display and check for leaks when re-starting and pressurizing the system. Your system is now ready to resume normal operation

Note: Disposal of fuel, associated waste, and filters must be in accordance with all applicable federal, state, and local rules, laws, standards, and regulations.

**!WARNING! Some fuels may have been treated with biocides. Biocides are extremely toxic and may enter the body through the skin. It is recommended to use adequate protection and proper precautions if fuel contains biocide type products.**

## Replacement Filter Chart

FPS SERIES FILTERS		ALL FILTERS ARE ABSOLUTE, UNLESS OTHERWISE NOTED   SS: STAINLESS STEEL SCREEN		
CARTRIDGE FILTERS				
	10μ	30μ	60μ SS	
FPS COMPACT	00510	00530	00560	
FPS FX	01010	01030	01060S	

# Troubleshooting

## Symptom Troubleshooting Guide

### No fuel delivery

1. Pump does not run
2. Pump is not primed
3. Fuel supply line blocked
4. Excessive lift
5. Air leak in fuel supply to pump
6. Pump rotation direction incorrect
7. Intake or outlet valve closed
8. Check valve installed backwards

### Insufficient fuel delivered

1. Air leak at inlet
2. Defective pressure relief valve or check valve
3. Excessive lift
4. Pump worn
5. Inoperative foot valve
6. Piping improperly installed or dimensioned
7. Primary filter/water separator plugged

### Rapid pump wear

1. Pipe strain on pump causing bind
2. Worn pump/motor coupler
3. Pump has been run dry or with insufficient fuel
4. Plumbing on inlet side not appropriately dimensioned

### Alarm “HIGH VACUUM ALARM” comes on with clean or new filter element installed

1. Heavily contaminated fuel/excessive water in tank
2. Restriction in plumbing on inlet side too high
3. Excessive lift
4. Inoperative foot valve
5. Inlet ball valve not fully open
6. Suction line clogged

### Pump requires too much power

1. Air in plumbing lines
2. Liquid too viscous
3. Bent pump shaft, binding rotor
4. Misalignment of pump/motor coupler

### Noisy operation

1. Insufficient fuel supply
2. Air leaks in the inlet pipe
3. Air or gas in fuel on the suction side
4. Pump and motor out of alignment
5. Worn out spider coupling
6. Pump coupler out of balance

### Motor does not turn or turns intermittently

1. Control power not available
2. Motor thermal overload condition
3. Pump failed and seized
4. Motor failure

### Pump leaks fuel

1. Loose pump plumbing fittings
2. Worn pump shaft seal
3. Pump pressure relief valve failure
4. Fuel leak elsewhere and fuel dripping or running towards the pump
5. Excessive head from overhead storage tank
6. Worn pump O-rings or seals

# AXI International Limited Warranty

AXI International makes every effort to assure that its products meet high quality and durability standards and expressly warrants the products described herein against defects in material and workmanship for a period of one (1) year from the date of purchase. This warranty is not intended to supplant normal inspection, care and service of the products covered by the user, and shall not obligate AXI International to provide free service during the warranty period to correct breakage, maladjustment, or other difficulties arising out of abuse, misuse, or improper care and maintenance of such products. Our express warranty is subject to the following terms and conditions:

This warranty shall only extend to and is only for the benefit of original purchaser(s), or end customer(s) who use the products covered hereby and subject to the terms and conditions herein. This warranty is not an on-site warranty. Travel requests will be at the discretion of AXI International. Defective systems and ancillary products will require a return authorization number and shipping to AXI International's factory in Fort Myers, FL. Any warranty claim received by AXI International after one (1) year from the date of purchase will not be honored even if it is claimed that the defect occurred prior to one (1) year from the date of purchase. Claims outside of this one (1) year period, and for claims not listed within, payment, repair, or service will be awarded at the sole and exclusive discretion of AXI International.

## **This Warranty shall NOT apply to the following:**

1. Damage or deterioration caused by normal wear and tear.
2. Failures caused by any external cause or act of God, such as accident, collision, theft, vandalism, riots, wars, re, freezing, lightning, earthquakes, windstorms, hail, volcanic eruptions, floods, tornados or hurricanes.
3. Failures due to alterations, adjustments, unauthorized changes to the product(s), neglect or improper storage, repair and/or maintenance.
4. Failures due to abuse or application of the product(s) for uses other than for which it/they are designed or intended by AXI International, including but not limited to, improper installation or location in a harsh, corrosive or saltwater environment.
5. Failures resulting from attachments, accessory items, and parts not sold by AXI International.
6. Repairs by any party other than those authorized by AXI International.
7. Failures resulting from user's delay in making the product available for inspection by AXI International after notifying AXI International of a potential product problem.
8. Cosmetic damage, discoloration, rusting, corrosion or scratches from applied paint.
9. Replacement of consumables such as, but not limited to, fuses, lamps, filters, etc.
10. Additional expenses for repair after normal business hours, i.e., overtime or holiday labor rates.
11. Expenses for rental of equipment during downtime and/or performance of warranty repairs.
12. Expenses related to investigating performance complaints and/or troubleshooting where no manufacturing defect is found.

In addition to the limitations above, this warranty shall not apply to products (1) which have been tampered with, altered or repaired by anyone other than AXI International without the express prior written consent of AXI International (2) which have been installed improperly or subject to misuse, abuse, accident, negligence of others, improper operation or maintenance, neglect or modification, or (3) which have had the serial number altered, defaced or removed.

The liability of AXI International under this warranty is limited to the repair or replacement of the defective product. AXI International assumes NO LIABILITY for labor charges or other costs incurred by any purchaser incidental to the service, adjustment, repair, return, removal or replacement of products. AXI INTERNATIONAL ASSUMES NO LIABILITY FOR ANY GENERAL, SPECIAL, INCIDENTAL, CONSEQUENTIAL, CONTINGENT OR OTHER DAMAGES UNDER ANY WARRANTY, EXPRESS OR IMPLIED, OF MERCHANTABILITY, FITNESS FOR A PARTICULAR PURPOSE OR OTHERWISE, WITH THE RESPECT TO THE PRODUCTS COVERED BY THIS WARRANTY POLICY, EXCEPT AS EXPRESSLY PROVIDED FOR HEREIN. AXI INTERNATIONAL ASSUMES NO LIABILITY FOR ANY GENERAL, SPECIAL, INCIDENTAL, CONSEQUENTIAL, CONTINGENT OR OTHER DAMAGES EVEN IF SUCH DAMAGES ARE A DIRECT RESULT OF AXI INTERNATIONAL'S NEGLIGENCE. NO EMPLOYEE, AGENT, REPRESENTATIVE OR DISTRIBUTOR IS AUTHORIZED TO MAKE ANY WARRANTY ON BEHALF OF AXI INTERNATIONAL OTHER THAN THE EXPRESS WARRANTY PROVIDED FOR HEREIN.





AXI International reserves the right at any time to make changes in the design, material, function and specifications of its products. Any such changes shall not obligate AXI International to make similar changes in such products that were previously manufactured.

To the fullest extent permitted by law, any claims against AXI International are limited to the remedies as expressly set forth in this warranty and any other further claims, such as but not limited to, compensation for any damage incurred other than to the AXI International product, are hereby excluded.

## Warranty Claim Procedure

To make a claim under this warranty, please call AXI International at +1-239-690-9589 or 1-877-425-4239, and provide: Name and location where unit was purchased, the date and receipt of purchase, model number, serial number, and a detailed explanation of the problem you are experiencing. The Customer Service Representative may, at the discretion of AXI International, arrange for a Field Engineer to inspect your system. If the inspection reveals a defect covered by its limited warranty, AXI International will either repair or replace the defective parts or products. AXI International assumes no liability, if upon inspection, AXI International or its representative determines that there is no defect or that the damage to the system resulted from causes not within the scope of this limited warranty and customer shall be responsible standard rates incurred by AXI International, as established from time to time by AXI International.

For service and sales, please contact AXI International:

AXI International | 5400 Division Drive Fort Myers, FL 33905  
Tel: +1-239-690-9589 | Toll Free: +1-877-425-4239 | Fax: +1-239-690-1195  
Email: [info@axi-international.com](mailto:info@axi-international.com) | Internet: [www.axi-international.com](http://www.axi-international.com)



# Technical Assistance and Ordering

Please write, fax, email or call:

AXI International  
5400 Division Drive  
Fort Myers, FL 33905  
Tel: +1-239-690-9589  
Fax: +1-239-690-1195  
Email: [info@axi-international.com](mailto:info@axi-international.com) Internet: [www.axi-international.com](http://www.axi-international.com)

**Please provide the following information:**

Serial Number of your FPS COMPACT, the required part numbers and quantity. The drawings/parts list included in this manual are the most accurate source of part numbers for your FPS COMPACT.

## Replacement Filter Elements

**Primary Filter/Water Separator:**

00560 - 60 $\mu$  Stainless Steel Reusable, Cleanable Filter Element  
00530 - 30 $\mu$  Replacement Filter Element  
00510 - 10 $\mu$  Replacement Filter Element

## FPS Compact System Identification

**Serial Number:** \_\_\_\_\_ (e.g. B090010-COMPACT)

**Inspected By:** \_\_\_\_\_ **Date:** \_\_\_\_\_