



MTC-3000 Instruction, Operating, & Maintenance Manual

MOBILE FUEL POLISHING SYSTEM

REV03033000010220

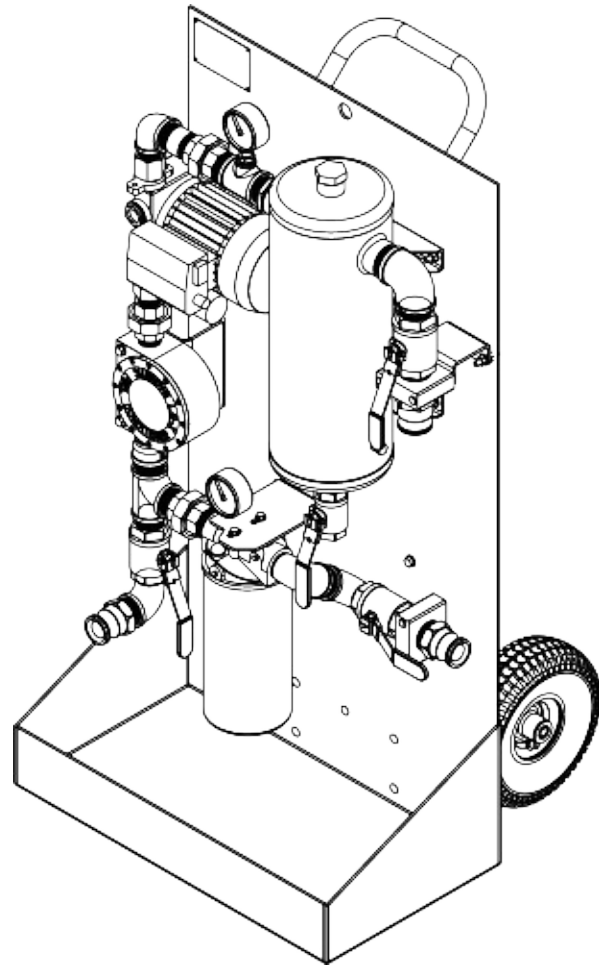



Table of Contents

Table of Contents	2
General Overview	3
MTC-3000 Specifications	3
System Components	4
Control and Safety Devices.....	4
Pump/Motor.....	4
Primary Filter/Water Separator	4
Fuel Conditioner.....	4
Fine Filter	4
Plumbing	4
System Operation	5
Setup Procedures	5
Phase 1	5
Phase 2.....	6
Phase 3.....	6
Draining and Storing the System	6
Primary Inspection	7
Checklist.....	7
Priming the System	8
Priming Procedure	8
Maintenance	9
Preventative Maintenance.....	9
Servicing the Pump	9
Servicing the Primary Filter/Water Separator.....	9
Servicing the Fine Filter	10
Replacement Filter Chart	10
Troubleshooting	11
Symptom Troubleshooting Guide.....	11
AXI International Limited Warranty	12
Warranty Claim Procedure.....	13
Technical Assistance and Ordering	14
Replacement Filter Elements	14
System Identification	14

General Overview

MTC-3000 Specifications

Nominal Flow Rate.....	26 GPM/1,560 GPH (98.4 LPM/5,905 LPH) 12,480 gallons (47,242 liters) per 8-hour run 37,440 gallons (141,726 liters) per 24-hour run
Primary Filter.....	Mechanical Water Separator
Secondary Filter.....	1, 3, 10, or 25 μ Fine Filter or 3, 10 μ Water Block
Fuel Conditioner.....	LG-X 3000 Inline Magnetic Conditioner
Plumbing.....	Black Iron
Inlet Port.....	1.5" Cam & Groove
Outlet Ports.....	1 1/4" Cam & Groove
Operating Temperature.....	41 - 104° (5 - 40°C)
Electrical.....	120V/60Hz/15A or 230V/50Hz/15A*
Pump/Motor.....	3/4 HP Rotary Vane Pump
Suction Capability (Primed).....	15ft. Vertical lift or 100ft. horizontal run (lines >1.5", primed)
Maximum Fluid Viscosity.....	5 cSt
Clear Suction Hose.....	1.5", 25 ft. (7.6 m)
Discharge Hose.....	1 1/4", 25 ft. (7.6 m)
Outline Dimensions.....	≈ 48" x 22.5" x 25" (122 x 57 x 63 cm) (H x W x D)
Weight.....	≈ 200 lbs. (90.7 kg)

*At 50 Hz., nominal flow rate decreases from 26 GPM/1,560 GPH to 20.8 GPM/1,248 GPH.

!WARNING! This system is not meant for use with gasoline or any other flammable liquids having a flash point less than 100°F (37.8° C). Use with gasoline or any flammable liquids at a temperature exceeding their flash point presents an immediate explosion and fire hazard.



System Components

Control and Safety Devices

- Vacuum & Pressure Gauges
- Inlet and Outlet Ball Valves
 - Inlet Ball Valve
 - Outlet Ball Valve (Discharge Port 1)
 - Outlet Ball Valve (Discharge Port 2)

Pump/Motor

- 3/4 HP Rotary Vane Pump
- Pump Strainer

Primary Filter/Water Separator

- Water Separator
- Drain Valve

Fuel Conditioner

- Inline Magnetic Fuel Conditioner

Fine Filter

- Standard-issue 3 μ fine filter cartridge (other filter elements available)

Plumbing

- Black Iron

System Operation

!WARNING! The whole system must be properly grounded for operator safety.

Note: It is recommended that only qualified, experienced personnel, familiar with this equipment, who have read and understood all the instructions in this manual should operate and maintain the system.

Setup Procedures

To establish either fuel polishing mode, the user must attach both system hoses to the system in the proper configuration. The Intake/Suction Hose is clear and see-through while the Discharge Hose is black and opaque. Both hoses are equipped with quick disconnect cam & groove couplings.

1. First, attach the quick disconnect end of the clear Suction Hose to the Inlet Port of the system.
2. We highly recommend attaching a straight wand or pipe (cut at an angle) to the end of the Suction Hose in order to reach the lowest part of the tank bottom.
3. The straight wand or pipe should be no less than the inner diameter of the Suction Hose.

Note: Never restrict the flow on the suction side of an MTC; e.g. by using a smaller ID hose or pipe attachment. This will lead to excessive pump load, noisy operation, and ultimately pump damage.

Bypass Mode:

In bypass mode, the fuel bypasses the system's Fine Filter(s) only to be ran through the Primary Filter/Water Separator for the bulk removal of water, sludge, and particulate. To establish bypass mode:

1. Attached the quick disconnect end of black Discharge Hose to Discharge Port 1 (located to left of the fine filter).
2. Before running the pump, ensure the Inlet Ball Valve and proper discharge ball valve (Discharge Port 1) are in the open position.
3. Also, ensure the other discharge ball valve (Discharge Port 2) and the Primary Filter/Water Separator drain ball valve are in the closed position.

Fine Filtration Mode:

In fine filtration mode, the fuel is run through the system's high efficiency spin-on Fine Filter(s) to remove free water and fine particulate as small as 1 micron. To establish fine filtration mode:

1. Attached the quick disconnect end of black Discharge Hose to Discharge Port 2 (located to right of the fine filter).
2. Before running the pump, ensure the Inlet Ball Valve and proper discharge ball valve (Discharge Port 2) are in the open position.
3. Also, ensure the other discharge ball valve (Discharge Port 1) and the Primary Filter/Water Separator drain ball valve are in the closed position.

Phase 1

AXI recommends 3 phases to successfully polish a fuel tank. This will ensure all contaminates are removed and the fuel is in optimal condition.

The goal of Phase One is to remove any free water and sludge from the bottom of the tank without mixing the water into an emulsified state within the fuel. The Pump will start pumping as long as the system is primed (See Priming the System section) and the suction lift is not excessive. The flow of the fuel can be observed in the see-through suction hose. Watch for a steady flow of fuel into the container.

1. Setup up the system in the Bypass Mode configuration (see the Setup Procedures – Bypass Mode).
2. Place the Discharge Hose into a separate discharge waste container.

3. To remove as much of the free water and sludge as possible, the Suction Hose (with a straight wand or pipe attachment) should be placed at the deepest part of the tank.
4. Turn on the Pump and be prepared to immediately switch it off once the fluid begins to fill the discharge container.
5. Inspect the discharged fluid and resume pumping until the bulk water and sludge have been removed from the tank bottom and only fuel is primarily discharged from the return hose.
6. Switch off the Pump and drain all water and debris from the hose and the Primary Filter/Water Separator (via the drain valve) into an appropriate waste bucket or container.

Phase 2

The goal of Phase Two is to remove any additional free water, sludge, and large contaminants within the tank. This phase will further clean the fuel and should be a precursor to using the more expensive spin-on filters. It should be noted that meeting required cleanliness codes is typically not possible with Phase One and Two alone. Phase Two is simply used to extend the life of the spin-on filters by removing the worst of the contaminants first.

1. Before turning on the Pump, ensure the system is still setup in the Bypass Mode configuration (see the Setup Procedures – Bypass Mode).
2. Remove the Discharge Hose from the waste container and place it into the tank.
3. If possible, ensure the Suction and Discharge Hoses are placed as far apart as possible but note that in many cases both hoses may have to be inserted through the same tank opening.
4. After verifying that both hoses are properly placed in the fuel tank and that the ball valves on the system are in the correct position, switch on the pump and watch the clear suction hose for fuel flow.

Note: Depending on the amount of contaminants in the tank, we recommend you stop the pump shortly after priming and check for free water and sludge by draining the water separator. It may be necessary to depress the air purge valve on top of the separator after opening the drain valve. Repeating this process and observing the fuel flow will indicate how long the pump should run before it is necessary to drain the separator.

5. The system should be kept running until clean fuel samples can be drained from the Primary Filter/Water Separator. Once this is achieved, switch off the pump to prepare for the final polishing phase.

Phase 3

Phase Three is the most important phase in meeting specific cleanliness codes. Unlike the Primary Filter/Water Separator, the spin-on Fine Filter typically uses an absolute rated media. Absolute filters have a very high efficiency and will ensure that fuel leaving the system is clean to specification.

1. Before turning on the Pump, ensure the system is setup in the Fine Filtration Mode configuration (see the Setup Procedures – Fine Filtration Mode).
2. After verifying that both hoses are properly placed in the fuel tank and that the ball valves on the system are in the correct position, start the pump and monitor the Pressure Gauge on the Fine Filter head.
3. When the pressure reaches 20 – 25 PSI or the needle reaches the red area on the Pressure Gauge it is time to change the Fine Filter (see the Maintenance – Servicing the Fine Filters section).

Draining and Storing the System

1. Remove the suction hose from the tank while the pump is still running and wait until system is purged of any remaining fuel.
2. Place an appropriate container under the Primary Filter/Water Separator and Discharge Port 1.
3. Open their respective ball valve and use the air purge valve on top of the separator to make sure all of the fluid can be drained from the system.



Primary Inspection

Upon arrival, the system and accessories must be visually inspected before installation. Improper handling during shipping may cause physical or electrical problems. Immediately report or note any damages to the shipper.

Checklist

- If the packing crate shows signs of damage inspect the system for damage.
- Check the entire system for damage that could indicate internal mechanical or electrical problems.
- Check pump/motor hardware and all plumbing connections for tightness.
- Check all electrical terminals and connections for tightness.



Priming the System

The pump supplied with the system is NOT automatically self-priming and must not be run dry.

!WARNING! If the pump is allowed to run without fuel, pump damage can occur.

Priming Procedure

Before turning on the pump make sure the entire suction side of the system (suction hose, primary filter/water separator, plumbing, and pump) is primed and filled with oil/diesel fuel. Running the pump dry could cause pump damage and pump to not operate properly.

Maintenance

The system should be visually inspected and tested a minimum of every six (6) months according to the procedure below during light duty cycles. Monthly inspections are recommended for systems that are being used in excess of an average of eight (8) hours a day and five (5) days a week.

Preventative Maintenance

Prior to performing the maintenance procedure ensure that:

1. All sources of power are isolated from the unit

Note: Proceed only after this has been verified and properly tagged.

2. Drain visible water and sediment from the primary filter (see Servicing Primary Filter/Water Separator).
3. Check system and all parts for corrosion and rust.
4. Check bolts on the pump/motor hardware for tightness, as pump/motor hardware can loosen after normal operation for extended durations of time, due to vibration.
5. Check all plumbing joints for leaks, tighten fittings and joints as necessary, and remove accumulated fuel in the leak-basin as necessary.
6. Inspect all filter(s) and separator.

Servicing the Pump

Check pump for leaks and worn vanes. We highly recommend carrying a spare pump. The MTC pump can be easily changed in a matter of minutes by opening the unions and/or short hose connections. Spare part kits are also available for all MTC pumps.

Keep the pump lubricated by pouring oil into pump head for storage.

Over time, the pump's strainer can collect debris. It is good practice to frequently check the pump strainer and clean it to prevent any flow restrictions.

Cleaning the Pump Strainer:

1. With the pump off, remove pump strainer cap on the pump/motor assembly with an adjustable wrench.
2. Once the cap is removed, fish out the mesh basket and rinse it off.
3. Once fully cleaned and dried, return the mesh basket to its original position and securely tighten the strainer cap.

Servicing the Primary Filter/Water Separator

It is recommended the Primary Filter/Water Separator be periodically serviced to prevent excessive water buildup. In the case of a severely contaminated tank, the Primary Filter/Water Separator can also become clogged with sludge and debris resulting in restricted fuel flow. The vacuum gauge reads the condition between the Primary Filter/Water Separator and the pump and should provide some indication of a clogged filter via a pressure drop reading.

Servicing of Water Separator:

1. Ensure the system's pump is turned off.
2. Close the inlet and outlet ball valves.
3. Place an appropriate container under the drain valve.
4. Remove the top plug to allow air in and fuel to flow out.
5. Open the drain valve and allow the water and sludge to drain.
6. Close the drain valve when you begin observing clean fuel.

Note: Disposal of fuel, associated waste, and filters must be in accordance with all applicable federal, state, and local rules, laws, standards, and regulations.

!WARNING!: Some fuels may have been treated with biocides. Biocides are extremely toxic and may enter the body through the skin. It is recommended to use adequate protection and proper precautions if the fuel at-hand contains biocide type products.

Servicing the Fine Filter

Clogged filter elements restrict the flow of fuel, resulting in the system’s pressure gauge indicating a pressure spike. The pressure gauge is mounted between the pump and the fine filter. A pressure reading of 20 - 25 PSI or when the needle reaches the red area on the pressure gauge will indicate when a filter change should be made on the system.

Changing the fine filter:

1. Ensure the system’s pump is turned off.
2. Close the inlet and outlet ball valves.
3. Place an appropriate container underneath the filter.
4. Remove the old spin-on filter with a filter wrench
5. Apply a film of lubricating oil to the gasket of the new filter. Screw the new filter canister to the filter head until the gasket is tight and secure (rotate the element an additional 0.5 – 1 turn after the filter makes contact with the gasket).
6. Open the inlet and outlet ball valves.
7. Check for leaks when re-starting and pressurizing the system.

Replacement Filter Chart

MTC SERIES FILTERS

ALL FILTERS ARE ABSOLUTE, UNLESS OTHERWISE NOTED | WB: WATERBLOCK | SS: STAINLESS STEEL SCREEN

SPIN-ON FILTERS							
	1µ B100/B10	3µ	3µ WB	10µ	10µ WB	25µ	3µ X-GLASS
MTC-1000	FF-1	FF-3	WB-3	FF-10	WB-10	FF-25	FFZ-3
MTC-3000	FF-1	FF-3	WB-3	FF-10	WB-10	FF-25	FFZ-3
MTC-X	FF-1	FF-3	WB-3	FF-10	WB-10	FF-25	FFZ-3

Troubleshooting

Symptom Troubleshooting Guide

No fuel delivery

1. Pump does not run
2. Pump is not primed
3. Fuel supply or return line blocked
4. Primary filter is clogged
5. Excessive lift
6. Air leak in fuel supply to pump
7. Intake or outlet valve closed
8. Liquid too viscous (thick)

Insufficient fuel delivered

1. Air leak at inlet
2. Defective pressure relief
3. Excessive lift
4. Pump worn
5. Flow restriction in hose/plumbing
6. Liquid too viscous
7. Filter plugged

Rapid pump wear

1. Pipe strain on pump causing bind
2. Worn pump/motor coupler
3. Pump has been run dry or with insufficient fuel
4. Plumbing on inlet side not appropriately dimensioned

Vacuum gauge shows more than 15”HG

1. Restriction on inlet side too high
2. Lift too high
3. Inlet ball valve not fully open
4. Suction line/Water Separator/Strainer/LG-X Fuel Conditioner clogged

Pressure gauge in red area or more than 20 – 25 PSI with clean or new filter element installed

1. Restriction on discharge side too high
2. Head (lift) on discharge side too high
3. Check filter for water saturation (WB only)
4. Outlet ball valve not fully open
5. Discharge line clogged

Pump requires too much power

1. Air in plumbing lines
2. Liquid too viscous
3. Bent pump shaft, binding rotor
4. Misalignment of pump/motor coupler

Noisy operation

1. Insufficient fuel supply
2. Air leaks in the inlet pipe
3. Air or gas in fuel on the suction side
4. Excessive pump load (vacuum > 15”HG)

Pump requires frequent re-priming

1. Pump cavitation
2. Plumbing air leaks
3. Lift too high
4. Leaking pump seal

Motor does not turn or turns intermittently

1. Control power not available
2. Motor thermal overload condition
3. Pump failed and seized
4. Motor failure
5. Vanes are binding

Pump leaks fuel

1. Loose pump plumbing fittings
2. Worn pump shaft seal
3. Pump pressure relief valve failure
4. Fuel leak elsewhere and fuel dripping or running towards the pump
5. Excessive head from overhead storage tank
6. Worn pump O-rings or seals

AXI International Limited Warranty

AXI International makes every effort to assure that its products meet high quality and durability standards and expressly warrants the products described herein against defects in material and workmanship for a period of one (1) year from the date of purchase. This warranty is not intended to supplant normal inspection, care and service of the products covered by the user, and shall not obligate AXI International to provide free service during the warranty period to correct breakage, maladjustment, or other difficulties arising out of abuse, misuse, or improper care and maintenance of such products. Our express warranty is subject to the following terms and conditions:

This warranty shall only extend to and is only for the benefit of original purchaser(s), or end customer(s) who use the products covered hereby and subject to the terms and conditions herein. This warranty is not an on-site warranty. Travel requests will be at the discretion of AXI International. Defective systems and ancillary products will require a return authorization number and shipping to AXI International's factory in Fort Myers, FL. Any warranty claim received by AXI International after one (1) year from the date of purchase will not be honored even if it is claimed that the defect occurred prior to one (1) year from the date of purchase. Claims outside of this one (1) year period, and for claims not listed within, payment, repair, or service will be awarded at the sole and exclusive discretion of AXI International.

This Warranty shall NOT apply to the following:

1. Damage or deterioration caused by normal wear and tear.
2. Failures caused by any external cause or act of God, such as accident, collision, theft, vandalism, riots, wars, re, freezing, lightning, earthquakes, windstorms, hail, volcanic eruptions, floods, tornados or hurricanes.
3. Failures due to alterations, adjustments, unauthorized changes to the product(s), neglect or improper storage, repair and/or maintenance.
4. Failures due to abuse or application of the product(s) for uses other than for which it/they are designed or intended by AXI International, including but not limited to, improper installation or location in a harsh, corrosive or saltwater environment.
5. Failures resulting from attachments, accessory items, and parts not sold by AXI International.
6. Repairs by any party other than those authorized by AXI International.
7. Failures resulting from user's delay in making the product available for inspection by AXI International after notifying AXI International of a potential product problem.
8. Cosmetic damage, discoloration, rusting, corrosion or scratches from applied paint.
9. Replacement of consumables such as, but not limited to, fuses, lamps, filters, etc.
10. Additional expenses for repair after normal business hours, i.e., overtime or holiday labor rates.
11. Expenses for rental of equipment during downtime and/or performance of warranty repairs.
12. Expenses related to investigating performance complaints and/or troubleshooting where no manufacturing defect is found.

In addition to the limitations above, this warranty shall not apply to products (1) which have been tampered with, altered or repaired by anyone other than AXI International without the express prior written consent of AXI International (2) which have been installed improperly or subject to misuse, abuse, accident, negligence of others, improper operation or maintenance, neglect or modification, or (3) which have had the serial number altered, defaced or removed.

The liability of AXI International under this warranty is limited to the repair or replacement of the defective product. AXI International assumes NO LIABILITY for labor charges or other costs incurred by any purchaser incidental to the service, adjustment, repair, return, removal or replacement of products. AXI INTERNATIONAL ASSUMES NO LIABILITY FOR ANY GENERAL, SPECIAL, INCIDENTAL, CONSEQUENTIAL, CONTINGENT OR OTHER DAMAGES UNDER ANY WARRANTY, EXPRESS OR IMPLIED, OF MERCHANTABILITY, FITNESS FOR A PARTICULAR PURPOSE OR OTHERWISE, WITH THE RESPECT TO THE PRODUCTS COVERED BY THIS WARRANTY POLICY, EXCEPT AS EXPRESSLY PROVIDED FOR HEREIN. AXI INTERNATIONAL ASSUMES NO LIABILITY FOR ANY GENERAL, SPECIAL, INCIDENTAL, CONSEQUENTIAL, CONTINGENT OR OTHER DAMAGES EVEN IF SUCH DAMAGES ARE A DIRECT RESULT OF AXI INTERNATIONAL'S NEGLIGENCE. NO EMPLOYEE, AGENT, REPRESENTATIVE OR DISTRIBUTOR IS AUTHORIZED TO MAKE ANY WARRANTY ON BEHALF OF AXI INTERNATIONAL OTHER THAN THE EXPRESS WARRANTY PROVIDED FOR HEREIN.



AXI International reserves the right at any time to make changes in the design, material, function and specifications of its products. Any such changes shall not obligate AXI International to make similar changes in such products that were previously manufactured.

To the fullest extent permitted by law, any claims against AXI International are limited to the remedies as expressly set forth in this warranty and any other further claims, such as but not limited to, compensation for any damage incurred other than to the AXI International product, are hereby excluded.

Warranty Claim Procedure

To make a claim under this warranty, please call AXI International at +1-239-690-9589 or 1-877-425-4239, and provide: Name and location where unit was purchased, the date and receipt of purchase, model number, serial number, and a detailed explanation of the problem you are experiencing. The Customer Service Representative may, at the discretion of AXI International, arrange for a Field Engineer to inspect your system. If the inspection reveals a defect covered by its limited warranty, AXI International will either repair or replace the defective parts or products. AXI International assumes no liability, if upon inspection, AXI International or its representative determines that there is no defect or that the damage to the system resulted from causes not within the scope of this limited warranty and customer shall be responsible standard rates incurred by AXI International, as established from time to time by AXI International.

For service and sales, please contact AXI International:

AXI International | 5400 Division Drive Fort Myers, FL 33905
Tel: +1-239-690-9589 | Toll Free: +1-877-425-4239 | Fax: +1-239-690-1195
Email: info@axi-international.com | Internet: www.axi-international.com



Technical Assistance and Ordering

Please write, fax, email or call:

AXI International
5400 Division Drive
Fort Myers, FL 33905
Tel: +1-239-690-9589
Fax: +1-239-690-1195
Email: info@axi-international.com Internet: www.axi-international.com

Please provide the following information:

Serial Number of your system, the required part numbers and quantity. The drawings/parts list included in this manual are the most accurate source of part numbers.

Replacement Filter Elements

Fine Filter:

- FF-1 - 1 μ spin-on filter cartridge (not water blocking)
- FF-3 - 3 μ spin-on filter cartridge (not water blocking)
- FF-10 - 10 μ spin-on filter cartridge (not water blocking)
- FF-25 - 25 μ spin-on filter cartridge (not water blocking)
- FFZ-3 - X-Glass 3 μ Absolute spin-on filter cartridge (not water blocking)
- WB-3 - 3 μ water blocking
- WB-10 - 10 μ water blocking

System Identification

Serial Number: _____ (e.g. B090010-MTC3000)

Inspected By: _____ **Date:** _____