

Max. Flow Rate: 79 GPH (300 LPH)

- Separ 2000 series water separators fuel filters are a simple solution to many different fuel related problems.
- Five separate stages of filtration ensure 99.9% water separation (Certified TUV Report using SAE J1839) at maximum flow.
- Low restriction reduces wear on fuel pumps and ensures full RPMs.
- Backflushable (cleanable) element reduces down time and costly element changes.
- Marine version with U.S. Coast Guard-accepted metal heat deflector.

INDUSTRIAL



MARINE



Shown: Industrial (left to right) 2000/5, 2000/5U
Marine (left to right) 2000/5D, 2000/5UD-G

Inlet / Outlet Connections

Single Unit: 3/4"-16 Straight o-ring SAE
Duplex Unit: Shipped with optional #8 Male JIC Flare
(other adapters available)
Inlet and Outlet Pipe connection 12mm.

Ordering Specifications

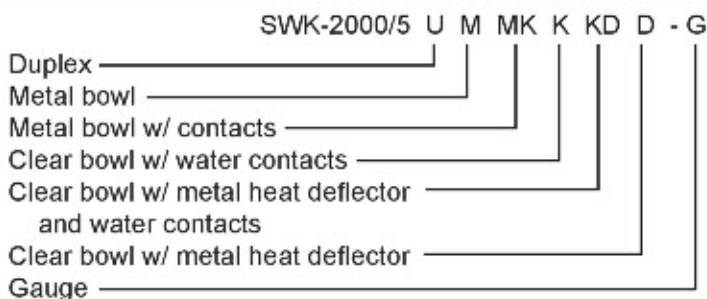

We reserve the right to alter the specification without prior notice.

Pressure Drop

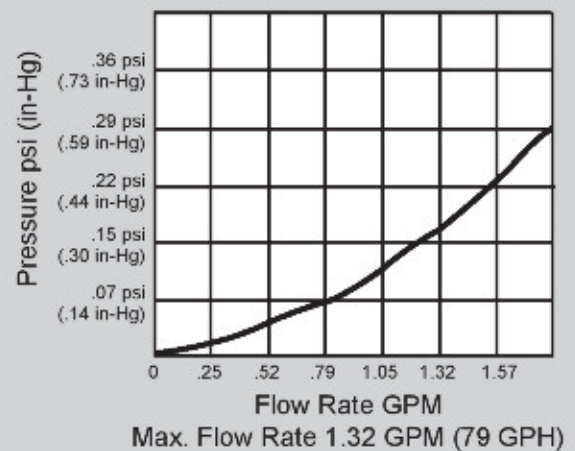

INDUSTRIAL

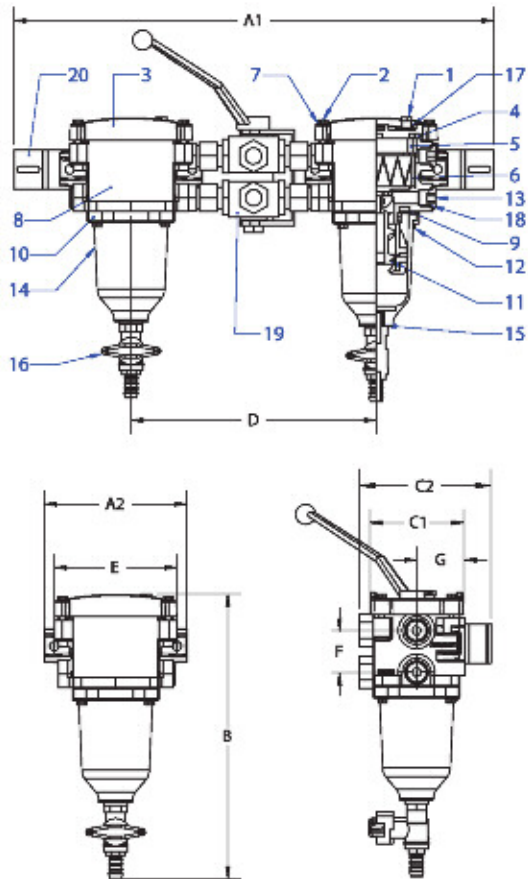

MARINE

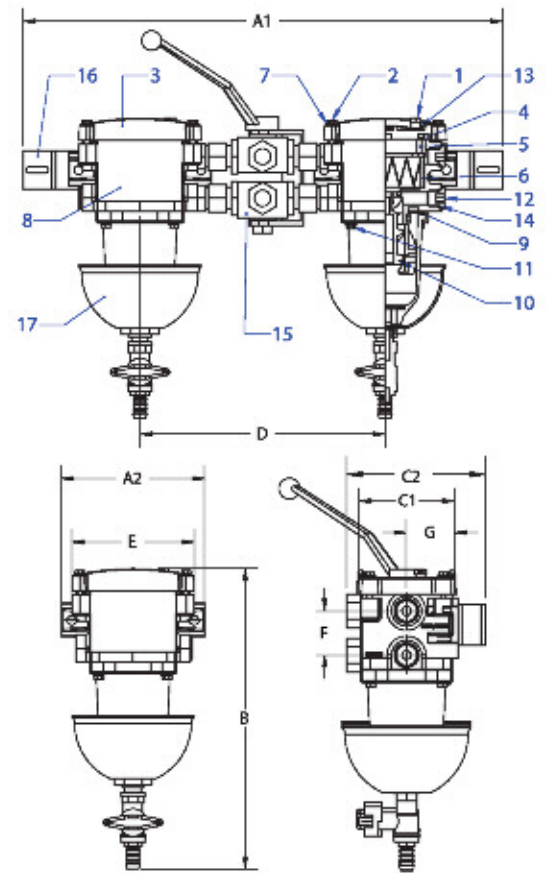

Item	Part #	Description	Dimension		Item	Part #	Description	Dimension	
1	30408	Bleed Screw	A1	18.5"	1	30408	Bleed Screw	A1	18.5"
2	FAB518220	Lid Screw		(469.9mm)	2	FAB518220	Lid Screw		(469.9mm)
3	30542	Lid	A2	5.51"	3	30542	Lid	A2	5.51"
4	10367	Lid Gasket		(140mm)	4	10367	Lid Gasket		(140mm)
5	30295	Spring Frame	B	10.98"	5	30295	Spring Frame	B	10.98"
6		<u>Filter Element</u>		(278.8mm)	6		<u>Filter Element</u>		(278.8mm)
	00510	10 Micron	C1	3.68"		00510	10 Micron	C1	3.68"
	00530	30 Micron (standard)		(93.5mm)		00530	30 Micron (standard)		(93.5mm)
	00560S	60 Micron (stainless steel)	C2	5.07"		00560S	60 Micron (stainless steel)	C2	5.07"
				(128.8mm)					(128.8mm)
7	30447	Washer	D	9.45"	7	30447	Washer	D	9.45"
8	30372	Housing		(240mm)	8	30372	Housing		(240mm)
9	10366	Bowl Gasket	E	4.72"	9	10366	Bowl Gasket	E	4.72"
10	30564	Retainer Ring		(120mm)	10	30548	Centrifuge		(120mm)
11	30548	Centrifuge	F	1.61"	11	30561	Bowl Screw	F	1.61"
12	30561	Bowl Screw		(41mm)	12	6408-08	Plug		(41mm)
13	6408-08	Plug	G	1.87"	13	30558	Bleed Screw Gasket	G	1.87"
14	30984	Clear Bowl		(47.5mm)	14	6408-08	Plug O-Ring		(47.5mm)
15	10360	Drain Valve O-Ring			15	2000_5-VA	Reversing Valve Assembly		
16	30366	Drain Valve			16	30475	Mounting Bracket		
17	30558	Bleed Screw Gasket	Model	Weight	17		<u>Bowl Assembly</u>	Model	Weight
18	6408-08	Plug O-Ring	SWK-2000/5	3 lbs (1.36 kg)		30988W	Single Unit (white)	SWK-2000/5D	4 lbs (1.81 kg)
19	30474	Reversing Valve Assembly	SWK-2000/5U	11 lbs (4.99 kg)		30988	Duplex Unit (grey)	SWK-2000/5UD	12.5 lbs (5.67 kg)
20	30475	Mounting Bracket							